

TANKLESS RACK SYSTEM™ SUBMITTAL SHEET: CORNER RACK



Job Name: _____

Location: _____

Architect/Engineer: _____

Wholesaler: _____

Model No.:	Gas Type:	Total System Btu/h:
------------	-----------	---------------------

Notes: _____

FEATURES AND BENEFITS

- | | |
|--|--|
| <ul style="list-style-type: none"> • Ultra-efficient condensing technology • Thermal Efficiency 97% • Modulating technology with up to 318::1 Turndown <ul style="list-style-type: none"> • 15,000 Btu/h to 4.18 Million Btu/h • 0.26 gpm to 235 GPM hot water flow range • Ultra Low NO_x - Complies with South Coast Air Quality Management District 14 ng/J or 20 ppm NO_x emission levels • Sealed Combustion • Venting Options: <ul style="list-style-type: none"> • Common Vent System PPTl, 8 units up to 150 feet • Concentric PPs - 150 ft max vent length • Dual Pipe PPs - 150 ft max vent length • PVC/CPVC - 2", 3", 4", 6" | <ul style="list-style-type: none"> • Pre-assembled rack with CU199 indoor or outdoor water heaters installed • Wall-mount or free-standing/floor mount options • Powder coated black iron gas pipe and copper water manifolds • Commercial controller available for hot water temperatures between 98°F and 185°F • Flexible stainless steel pipe connections from hot and cold manifold/water heater connections • Individual drain tee/drip leg on gas connection for each water heater • Marine grade powdered coated aluminum frame • TRS fits through standard 32" doorway • Lifting eyebolts on free-standing racks • Isolation and pressure relief valves included and installed on each water heater |
|--|--|

OPTIONS

Natural Gas	Corner Rack	Cascade Cable (up to 24 units)
Propane		EZConnect® (for 2 units only)

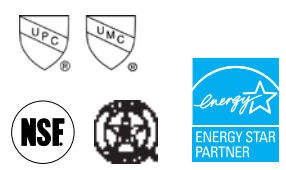

CORNER-HANGING RACKS

Available Configurations

- 2-Units

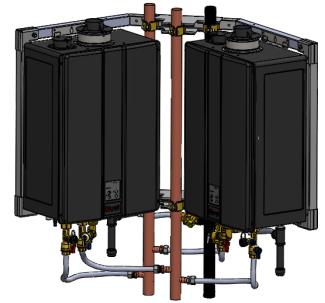

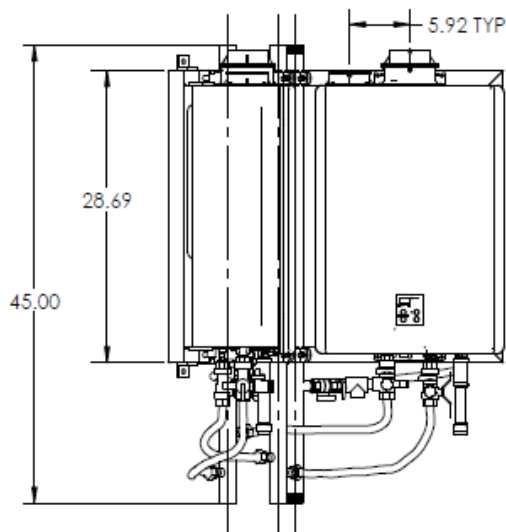

2-Unit Corner-Hanging Frame

FRONT

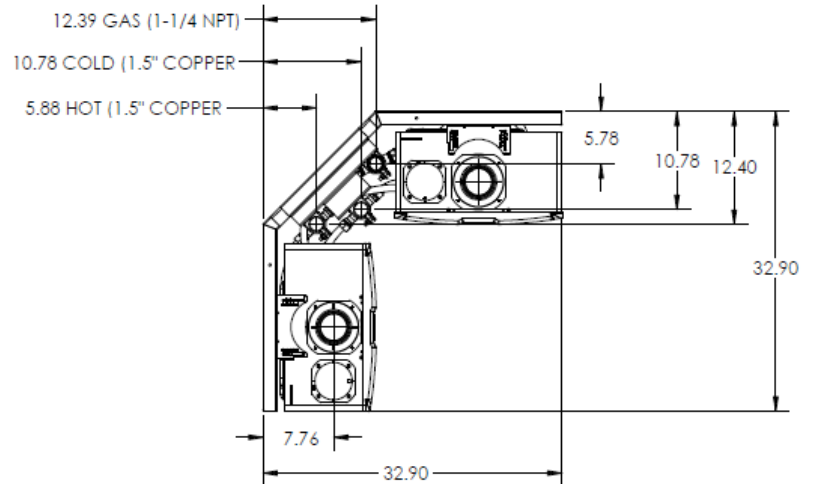

TOP

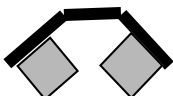

Model	Configuration	Illustration
TRC02CU		

2-Unit Corner-Hanging Frame (Continued)

Model	TRC02CUI
Water Heater Model	CU199i (NG/LP)
Crate Dimensions (HxLxD) - in	31.5 x 48 x 50
Weight - Fully Assembled - lbs	224
Weight - Shipping (total) - lbs	356
Rack Frame - Specifications	
Frame Material	14 Gauge Hot Rolled Steel 1.5" Square Tube
Frame Finish	Powder Coat
Color	Gray
Water & Gas Connections	
Hot Water Trunk Line Diameter	1-1/2"
Cold Water Trunk Line Diameter	1-1/2"
Hot Water Trunk Line Material	Rigid Copper
Cold Water Trunk Line Material	Rigid Copper
Water Trunk Connection Type	1-1/2" PIPE
Gas Trunk Line Diameter	1-1/4"
Gas Trunk Connection Type	1-1/4" MNPT
Gas Trunk Line Material	Sch 40 Steel
Gas Branch Line Material	PVC Over CSST
Electric Requirements	
Voltage	AC 120 Volts—60 Hz
Maximum Current (Amperes)	8
BTU and Flow Rates for CU199i, (NG/LP)	
Number of Tankless Water Heaters	2
Flow rate @ 70°F rise (gpm)	10.8
Flow rate @ 100°F rise (gpm)	7.6
Minimum input rate (Btuh)	15,200
Maximum input rate (Btuh)	398,000

